

BANGERS

2009 TRACKSTAR REGULATIONS

1. Type of Car

You must use any four wheel, right-hand drive, saloon, coupe or estate car or People Carrier within the specified main weight categories taken from MOT Brake Weight Chart.

The car must have an all-steel body which may not be cut lowered, narrowed or shortened. Further restrictions may apply to any weight range such as non Ford, cc limits etc. No SUV's or 4 x 4 vehicles allowed.

2. Stripping

Remove all glass and interior trim including door linings, head linings and all floor covering.

It is strongly advised to pad steering columns with high density foam

- Remove all seats except the driver's which must be retained, the use of a racing seat is not allowed.
- Remove all exterior trim, chrome and plastic strips, door handles, external mirrors, wheel trims and weights.
- Remove over riders from both front and rear bumpers.
- Remove any towing bar or towing attachments, spare wheel carriers.
- Wherever possible fuel tanks must be removed. If however, the tank is an integral part of the body you must remove as much as possible.
- Only the original standard steel bumper can be used. If a front bumper is fitted, a maximum of three additional bolts may also be fitted to secure it in place. No wrap around bumpers are allowed. Plastic bumpers must be removed. All cars with deep impact style bumpers must have the bumper and retaining irons removed before racing e.g.; Volvo 2 series and Saab, you may fit a Cortina type bumper in its place.

3 Roll Bar

- You must fit a single "hoop" roll bar in support of the door pillars, securely bolted to the roof and floor with a minimum size bolt of 3/8" (8mm) and suitable washers.
- The roll cage must be fitted upright not leaning back or forward.
- It is strongly recommended that roll cages are padded, including the B pillar.
- The hoop must be one piece or two uprights on one top bar of a welded construction.
- One cross bar is compulsory, a second is optional, these must be welded or bolted to the uprights.
- Roll cage feet must be flat steel with no bracing and must be welded to the two uprights. The roll bar feet must be no larger than 12 x 12 inch.
- THE ROLL BAR MUST NOT HAVE ANY REAR SUPPORTS but may have extensions no further forward than the B post (see diagram below). If used, these must be bolted through the B post.

- It is highly recommended that the frame is bolted through both sides of the car.

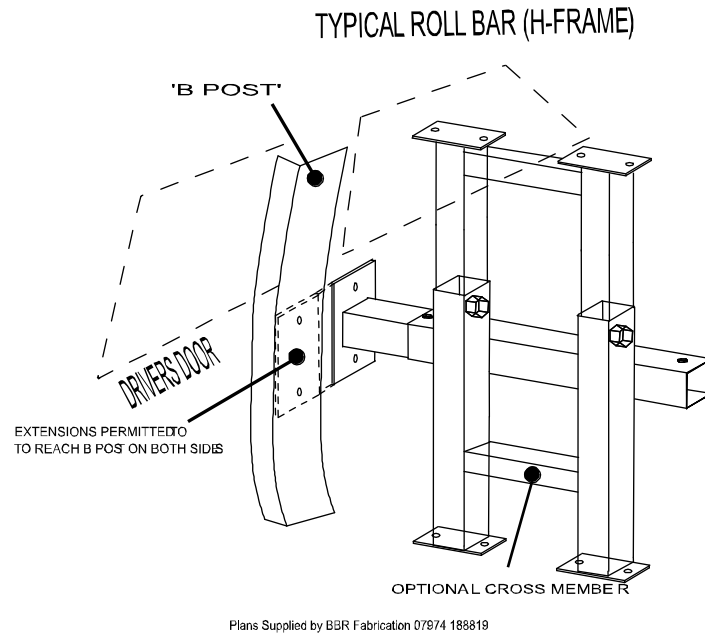

- The minimum size for roll bar is 2" (50mm), maximum size 4" (100mm), and minimum thickness 3" (75mm).
- Crossbars must have a 5" (125mm) square end plate fitted.
- The roll bar must be straight, or extended forward to the B pillar and bolted through the pillar.
- Each upright must have a minimum of two bolts on each side to the floor and one each side at the top.
- You must tie the seat at shoulder level to the roll cage or B pillar, through the seat frame not headrest, you may fit the 2nd cross bar in support of the seat just below the window aperture or weld a frame on the cage to support the seat at the top.

4. Strengthening

- All doors must be secured shut.
- The driver's door may be welded with no restriction on the amount of welding used. Box section is allowed in the lower window aperture of the drivers and rear drivers door, not extending further than the rear of the H frame. Please note this is not allowed on the passenger side (Including Pillarless Cars).
- All other doors must be secured by bolting or chains. Maximum number of bolts permitted is 4 per door.
- Where plates are used to secure doors other than the driver's door, then these must be a maximum of 12" x 12" and fitted with a maximum of 5 bolts, minimum size 1/4" (6mm).

- Triangular corner plates or straps may be used to secure the rear of the bonnet by bolting or welding (1/8" thick.) Plates or straps must be placed no further than 20" across or down from the back edge and side of the bonnet.
- Bonnets must be bolted down using a maximum of four bolts, 2 bolts in either side of the bonnet, with a minimum of 18" between the front and rear. Maximum height of bolt above the washer is 1 1/2". Bonnets must not be moved forward or overlapped. (4 bonnet bolts must be used!)
- These bolts must not pass through the chassis or be attached to the suspension bed.
- Front bolt must go through the slam panel or inner wings and you may use crush tubes, when crush tubes are used, they must be a maximum of 2" outside diameter tube.
- Rear crush tubes may be secured in place by one bolt but not welded. Front crush tubes cannot be secured by either bolting or welding.
- Crush tubes may be a maximum of 2"(50mm) outside diameter tube or 2" (50mm) box, maximum 5mm wall thickness.
- Crush tubes and washers must be separate items, i.e. the tube cannot be welded to the washer.
- Maximum size of bolt or studding is 1", including shouldering. Cam wheels may not be used as bonnet washers. Maximum size of the washer is 7" x 5".
- Maximum length of chain if used is 24".
- Shuttering bolts may only be used for bonnet bolts providing they don't protrude past the top of the wing nut by 1/2 inch, and are taped up to ensure they do not come loose. These are not recommended and may not be allowed by some promotions – please check with the promotion.
- Boot lids or rear door on estates may be chained or bolts using a maximum of four bolts, one in each corner, maximum size 3/8" or 24" of chain.
- All cars must start the meeting with the wings covering each wheel.
- Front wings may be folded and an additional 2 bolts may be added to secure the wing.
- All cars should have the complete dashboard removed if possible. You may be required to make an additional brace to secure the steering column. However this is mandatory if the standard support is removed i.e. cross bar on a Mondeo.
- No screen bars allowed.

The Promotion have the right to refuse any car which has more welding or bolts than necessary. The driver must present his car for scrutineering with the bonnet and bolts but they must NOT be fixed to the car.

- You are not allowed to strengthen the gearbox tunnel.
- Expanding foam or any other material may not be used to fill chassis or door sills etc.
- Sunroofs must be bolted or welded. If covered, the maximum thickness of the plate is 3mm, the maximum size of the plate is 4" larger than the sun roof opening. If a plate is fitted it must not be bolted to the roll cage.
- You may strengthen the TCA (the steering adjustment arm on the steering rack) by welding or sleeving.
- Suspension legs may be welded to the hub.
- No additional strengthening of any other suspension parts is allowed.
- Ford Granada or Cortina type sub frames may be secured with washers; Jaguar or Rover Coupe type sub frames may be secured by bolting or tack welding to the width of the mounting only.

5. Door Plates and Floor Plates

- A steel plate 10" to 15" deep $\frac{3}{8}$ – $\frac{3}{4}$ " thick must be bolted over the driver's door. This must be fitted with a minimum of 3" and a maximum of 6" past the A & B pillars securely bolted with a minimum of 4 bolts. There must be at least 1 bolt through the A pillar and one must be through the B pillar or through the B pillar or through the roll cage. The bolt size must be at least 16mm studding or bolt. (Only flat plate is allowed, no channel, angle or corrugated steel allowed). 8mm is the smallest size bolt allowed on all other bolts except A & B pillar.
- For 2 door cars (no B pillar), the door plate MUST be bolted through the roll cage.
- A steel plate fitted to the drivers floor pan is highly recommended. It must be no thicker than 6mm, and must be bolted and/or welded in. This may be modified to rise to the maximum height of the door sill of the door side only. A 4" steel plate no thicker than 6mm bolted through the A pillar to the door plate can be welded or bolted to the floor plate.
- It is not permitted to cut slots in the driver's doorplate, holes for bolts only.

6 Fuel System

- Manual fuel pumps may be replaced with electric pumps.
- The original petrol tank must be removed and replaced with a maximum size 2-3 gallon safety tank fitted inside the car either on, under or behind the roll bar, not on the parcel shelf. Before fitting, the tank should be carefully checked to see that it cannot leak when inverted or on its side and the outlet must be from the top of the tank. The vent pipe from the top of the tank must be terminated below the floor level of the car. The fitting of a one way valve is advisable.
- All fuel lines must be in good condition and securely clamped.
- A manual shut-off tap must be fitted within reach of the driver when strapped in the car.
- All fuel tanks must have a metal screw top.

7. Electrical System

- Batteries must be bolted or clamped in position and completely covered with rot-proof material to prevent acid leakage. Batteries should be fitted on, under or behind the roll bar, not in the foot well. If batteries are secured in a box the maximum size is to be 18" x 12" or equivalent.
- Alternators, if fitted cannot be wired to charge.
- All wiring must be fully insulated.
- Electrical starters must be fitted and in working order.
- Ignition and starting must be activated through an insulated switch, not by connecting bare wires together. A battery cut off switch MUST be mounted on the roll cage on the near side of the car, the switch must be wired to the earth side of the battery AND MUST BE WORKING.
- Electronic ignition is permitted within the manufacturers range e.g. Ford – Ford.

8. Cooling System

- Any modifications must be within the original bonnet outline.
- L shaped water tanks must end 6" behind the front of the engine block on rear wheel drive vehicles.
- Oblong and L shape tanks must not be fitted in front of the engine, the tank must be no further forward than 2" from the front face of the head on front wheel drive vehicles.
- These tanks must only be secured by 4 fixings and may not be welded into the car.
- Tanks along the bulkhead may only be extended in an L shape on one side of the engine.
- The front of the engine is classed as the block not the pulleys or water pumps etc.
- No cutting of bulkheads allowed.
- Tanks must be non-pressurised.
- An overflow pipe, minimum size ½", must be fitted on the driver's side and terminate within 9" of the floor on the driver's side.
- The bonnet must not be cut or altered to fit water tanks.
- Any car or light commercial radiator may be used, fitted under the bonnet.
- Water outlets may be modified but not armoured.

9. Engines, Gearbox, Propshafts and Exhaust Manifolds,

- The engine and gearbox must be the one originally fitted to the range as manufactured.
- The external parts of the engine must remain standard.
- The internal parts of the engine maybe modified.
- Engine and Gearbox mountings may be replaced or strengthened, but must occupy the original fixing positions.
- Vernier wheels are allowed.
- Additional gearbox mounts are only allowed on rear wheel drive cars. On front wheel drive gear box mounts must occupy the original position but can be strengthened.
- Flywheels may be modified.
- Clutches are free.
- The Mk1 and Mk2 Granada's are allowed to interchange the V6 Engines and gearboxes.
- Propshafts may be modified.
- Charging system, power steering pumps, air-conditioning pumps amd fan blades may be removed.
- No turbos, no superchargers or other fuel injection, (except diesel).
- No dry sump systems.
- A complete metal firewall must exist between the driver and engine compartment.
- No armoured cam, distributor guards or water outlets.

- Any standard cast exhaust manifold which fits the engine may be used.
- Cars which are produced with a fuel injected engine may be used fitted with the same or smaller size carburettor engine from an earlier range i.e The Ford Mk3 Granada may be used supplementing the 2.9ltr with the 2.8 or 2ltr engine with carburettor.
- The 2 Litre Pinto engine may be used in any RWD car as long as this is no larger than the original engine.
- Engine mounts may be strengthened but must remain in the original place if fitted. No additional mounts allowed. Modified mounts can be welded to the cross member, but must be bolted if attached to the chassis.
- On transplanted engines the position of the mounts on the engine are free, but the rule on chassis or cross member mounts is as above. The purpose is to hold the engine and not strengthen the car. Every part must be behind the front of the engine and not used for armouring.
- No additional metal is allowed on the chassis to mount the engine, and engine mounts must not protect water outlets or distributors etc
- Top left engine mount on a Mondeo must be of the same size as the original.

10. Carburettor / Inlet manifold

Fuel injection engines may be converted to carburettors if the engine is manufactured in both forms as standard. Inlet manifolds may be modified. eg the 2.9 V6 can be used with the 2.8 inlet and carburettor, or Cavalier with the earlier style inlet manifold.

- Carburettors may be replaced with the equivalent size Weber conversion as per specification below. Adapter plates may be fitted by bolting or welding (max size carburettor allowed is 32/36 as fitted to 2 Litre Ford).
- Vehicles fitted with a single point injection can be used providing they are fitted using the standard Banger fuel system and the fuel pump is replaced with a standard High Pressure Facet pump.
- Cold starting devices may be removed.
- Jets may be changed.
- Replacement Spindles with standard screws may be fitted, no polishing or reproofing allowed, no modifying or enlargement of any fuel galleries allowed.
- Floats must not be modified or weighted and needle valve must remain standard size, enrichment or power valve must be fitted and working.
- Note; The Solex or Pierburg carburettor may be replaced with the equivalent size Weber conversion as above specification.
- All carburettors must have a visual secondary fixing on the fuel inlet pipe.
- Air filters may be removed or replaced by competition type.
- The 3ltr or 2.8ltr carburettor is not allowed on the Ford o.h.c. Pinto engine.
- The 3ltr carburettor may be fitted to the 2.8 Ford Engine.

11. Wheels and Tyres

- Any standard steel or alloy wheel up to 6½"J that fits safely may be used.
- You may only use conventional road tyres up to 195. The lowest profiles "60" series (on unlimited meetings only, conventional road tyre up to 235 "60" series may be used.). Tyre gaiters are allowed.
- All tyres should have a minimum durometer reading of 60, whenever tested.
- No Yokohama, Avon 7.3 wide safety, town and country, M & S, Kingpin Alpine Series competition type or cut tyres. All wheel nuts must be fitted. The ORCi reserve the right to ban any tyre make or type which give an unfair advantage.
- The use of Weller style steel wheels to the max size of 6½"J are permitted on any car.
- Cut and shut or banded wheels are not permitted. No wheel weights.

12. Suspension, Brakes and Axles

- Suspension components must remain standard, lowering is allowed by cutting, heating or changing of springs only.
- Shock absorbers must be standard type as fitted originally. No interchanging of suspension parts allowed.
- Bump stops may be removed and the only adjustment allowed are those which can be achieved within the manufacturer's original design. Cross members must not be altered or redrilled.
- All suspension mounts must be in the original position.
- Brakes must be effective.
- Back axles must be standard to the car with no additional strengthening.
- A secondary fixing is required on coil springs that may fall out, chain or wire should be used – not welding.
- The tack welding of anti-roll bar brackets is allowed.
- All suspension rubber mounted tops may be secured with a larger washer than original. These must not be welded.

13 Differentials

- Ratios are free but must be standard to the range.
- No limited slip differentials allowed, even if fitted as standard.
- Power locked differentials are allowed if fitted as STANDARD to the car, and NOT as an optional extra.
- Differential must be unlocked except on shale or dirt tracks.
- Axle casings must not be welded or reinforced.

14 Exhaust Systems

- Wherever possible the original exhaust system must be retained with the last 2 foot removed.
- If the original system has to be replaced there must be at least one silencer to each exhaust pipe and at least two secondary fixings after the manifold.
- The original mount must be supplemented with at least one additional fixing to secure the system to the car.
- No car will be allowed to race without an exhaust system and all drivers must be aware that if your car is above the required noise level you will not be allowed to race.

15 Safety Equipment

- A full shoulder – type safety harness as approved by ORCi for Bangers with lap-straps must be fitted and bolted to the floor.
the floor or cage (including the seat bar) are recommended anchor points.
- Single point buckle fixing harnesses are not be allowed.
- A suitable head restraint must be fitted to the roll cage or seat.
- A 1Kg Dry Powder Gauge Fire Extinguisher is highly recommended and if fitted, this should be in a tube with a spring top and should be within easy reach of the driver. Old type BCF (green) type extinguishers are not allowed. All tow vehicles, must carry a minimum of a 2kg fire extinguisher dry powder or gas, which must be within easy reach of the driver and mechanics at all times, especially when refueling.
- Helmets must be of a minimum standard as directed by British Oval Racing Safety Executive (B.O.R.S.E). These are BS6658/85 Type A, BS6658 Type A/FR, FIA8860-2004, Snell SA2000, Snell SA2005, SFI Foundation 31.1A, SFI Foundation 31.2A. The E2205 European standard helmet may be used in Fibreglass or Tri-Composite form only. It should be noted that from 2010 the Snell SA2000 and the BS6658 Type A will be obsolete. It is important that the helmet fits the driver correctly. Shatterproof goggles/visors must be worn although tinted visors are not advisable.
- Neck braces are recommended.
- Fireproof Balaclavas are highly recommended and must be marked appropriately.
- Fireproof gloves are MANDATORY and must be marked appropriately.
- Only flame retardant racing suits must be worn. On wet meetings waterproofs may be worn as overgarments.
- The driver's seat must be secured and supported to the roll cage at shoulder level by bolting or tying.
- The 2nd roll cage cross brace may be used to support the seat, but it must be set below the bottom of the window aperture or you may construct and weld a frame on to the cage to support the seat.
- The driver's seat must be a standard production seat, not a racing seat.

16. Numbers

- You must fit a fin plate to the roof of your car, minimum size 18" x 12" and a maximum size of 20" x 15".
- Your number must be either white on a black background or black, on a white background, no other colours allowed, no other writing allowed, minimum size 9" high x 1½" wide.

- You may also paint your number on each side of the car in contrasting colours.

17. Roof Grades

- Your grade colour must be painted on the whole roof of your car.

World Champion	Gold
1600 Bangers National Champion	Red & Yellow Checked
National Points	Silver
SuperStars	Red Roof + flashing lights
Star Grade	Red Roof
A Grade	Blue Roof
B Grade	Yellow
C Grade	White

18. Supplementary Rules (For Special Meetings)

Your promoter will state either via the fixture list or special entry form at which meeting this rule can be used and therefore cannot be used by a driver regardless of type of car at a normal meeting!!

Engine Transplants

- On Unlimited Meetings. The 2ltr Ford o.h.c. engine and gearbox can be used in place of the original engine in any car, other transplants may be allowed but only with permission of the staging promoter. They must be the same or lower c.c.

Engine mounts may be strengthened but must remain in the original place if fitted. No additional mounts allowed. Modified mounts can be welded to the cross member, but must be bolted if attached to the chassis.

- On transplant engines the position of the mounts on the engine are free, but the rule on chassis or cross member mounts is as above. The purpose is to hold the engine and not strengthen the car. Every part must be behind the front of the engines and not used for armouring.

- No additional metal is allowed on the chassis to mount the engine, and engine mounts must not protect water outlets or distributors etc.

Suspension and Steering

- Parts may be interchanged with the permission of the staging promoter.
- Left hand drive cars may be allowed at the staging promotions discretion.

19. Van Meetings

All rules apply, the roll cage must be to the full specification, the drivers seat must be secured at shoulder height to the door pillars or cage. Each promotion may have additional regulations- please check.

Large Vans Roll bar to the full specification or the single bar fitted centrally behind the drivers seat, plated top and bottom, minimum 4 bolts per plate.

20. Micro Bangers

- All usual rules apply and additionally you may fit a distributor guard to the following specification.
- The maximum width of the guard is 9", with a maximum thickness of ¼".
- The plate may be for the full depth of the engine, bolted or welded to the sub-frame and or gearbox and at the top braced back to the front of the head using box iron, no bigger than 1" x 1". It is only permitted to use a distributor guard on a front facing distributor i.e. a series engine.
- The driver's seat must be secured at shoulder height to the door pillars or cage fitted.
- Metro rear sub frames may be secured by an additional two bolts as a secondary fixing.

21 Fitness

- Any driver who has suffered concussion as a result of an incident during a race will not be permitted to engage again in that meeting.
- Any driver for whom a race has been stopped or suspended because he/she has given the Steward cause to believe that he/she may be injured, will be excluded from the rest of the meeting for medical reasons.

22. Final Preparation

- The external painting of the car should be in bright colours. Any colour schemes are permitted. Rusty or dirty vehicles will not be allowed out onto the circuit. Rude or provocative slogans are not allowed. In addition to the car construction rules, all cars presented at scrutineering must be considered safe and not unsightly.

23. Main Weight Categories

(taken from the MOT Brake Weight Chart)

UNLIMITED BANGERS minimum 2 Litres

- Minimum weight 1450kg – no upper limit
 - Lightest car allowed is a Mk3/4 Granada
 - All cars to be rear wheel drive with the exception of Yanks which may be front wheel drive
 - Standard engines – no tuning allowed
 - Engine swaps permitted
- Yank allowed
- (Cortinas, Sierras, Bluebirds etc are not allowed)

T.S.R. Domestic classe

Under 2 LITRE BANGERS

up to 2 Litres

- Guideline weight range for this formula is 1100kg – 1560kg on the MOT brake weight chart (ORC National Banger middle weight range)
- Regardless of the weight range above, the following cars over 1100kg are NOT allowed in 2 Litre Bangers because of the safety risk associated with their smaller size – Alfa Romeo 33, Austin Maestro, Citroen Xsara, Daewoo Nexia, Ford Escort/Orion, Fiat Tipo, Honda Ballade, Honda Civic Shuttle, Hyundai Pony, Lada Riva, Mazda 323, Mitsubishi Colt, Mitsubishi Lancer, Morris Ital/Marina, Nissan Sunny/100NX, Renault Megane, Proton Persona, Rover 213/216 (early square model), Skoda Felicia, Suzuki Baleno, Talbot Horizon/Solara, Vauxhall Astra/Belmont, Volkswagen Golf
- The following cars at the upper end of the weight range are not allowed in 2 Litre Bangers because they are more suitable for Unlimited Banger racing – Ford Granada Mk1/2, Mazda 929, Nissan Laurel, Rover SD1, Toyota Cressida, Volvo 1-series, 2-series and 7-series
- Special notes – Saab 99/900 are not allowed. Ford Granada Mk3/4 may be used but NOT Mk5/Scorpio. (Because these cars have been allowed at previous meetings, the Mk5/Scorpio will be outlawed from 1 July 2009). The only 5-series BMW which falls in the above weight range and may be used is the early E28 series 518/520.
- Standard engines – no tuning allowed
- Any car may use a 2 litre pinto engine as long as this is the same size or smaller than the original. Other engine swaps must be from the same manufacturer (e.g. Vauxhall – Vauxhall, Toyota – Toyota, etc)

Under 1500cc Bangers

- Fundamental ruling is that the car to be raced must have been available from the manufacturer with an engine of 1500cc capacity or less AND is not small enough to be eligible for Micro Bangers
- Engine limit is 1600cc maximum for all cars (e.g. no Stellar, Bluebird, Carina, Primera, Integra, Accord etc as none of these were available smaller than 1600cc, but 1600cc Astra, Cavalier, Civic, Rover 200 all OK as these were also available with smaller engines conforming to the rule above)
- Guideline weight range for this formula is 950kg – 1250kg on the MOT brake weight chart but the rules above take precedence over this weight range
- Heavier under 1500cc cars (e.g. FSO Polonez, Austin A55 Cambridge, Riley 4/68) may be allowed at the discretion of the promoter – please phone and check before building your car)
- Standard engines – no tuning allowed
- Ford Capri and Cortina are limited to 1300cc crossflow (no 1600 pinto engines)
- Any car may use a 1300cc crossflow engine as long as this is the same size or smaller than the original. Front wheel drive cars may use engine swaps from the same manufacturer (e.g. Vauxhall – Vauxhall, Toyota – Toyota, etc)

Distributor guards must not be fitted to 2L Bangers and 1500cc Bangers

MICRO Bangers

- 1500cc maximum
- Cars allowed are Mini, Metro, Fiesta, Nova, Renault 5, Corsa, Peugeot 106, Micra, Citroen AX, Kia Pride, Starlet, Clio, Uno and similar size
- Excluded (too large) are Triumph Acclaim, Ford Escort, Astra, Fiat Tipo, Nissan Cherry, Hyundai Pony and similar
- Distributor guards may be fitted to Mini and Metro only
- Please contact the TSR office to check any cars not listed are eligible to race

General Banger Racing Rules.

There will be an automatic minimum three month ban which will be issued for threatening behaviour, and a minimum of 12 months which will be issued for physical violence offences, second offences will have a harsher penalty. This applies to all drivers and team members in all formulae.

1. Helmets must be of a minimum standard as directed by British Oval Racing Executive Safety Executive (B.O.R.S.E.) These are BS6658/85 Type A, BS6658/85 Type A/FR, FIA 8860-2004, Snell SA2000, Snell SA2005, SFI Foundation 31.1, or SFI Foundation 31.2 or E2205 European Standard. Plastic or Polycarbonate helmets (ie British, European or Snell) of any type are not permitted. Shatterproof goggles/visors must be worn although tinted visors are not advisable.
2. Flame retardant racing suits are compulsory. Neck braces are recommended. Fireproof Balaclavas are highly recommended and must be marked appropriately. Fireproof gloves are MANDATORY and must be marked appropriately.
3. All flag signals must be obeyed immediately.
4. Drivers who appear to have indulged in the intake of alcohol or drugs will be excluded from racing. Smoking is not permitted in cars, on track or in the pits at any time.
5. No passengers are allowed in the car. The driver may only travel on the car on a parade or lap of honour. In some cases passengers who are safely on the car may be allowed to accompany the driver
6. Banger racing is a full contact sport, drivers can race to win or attempt to win by stopping the opposition. All heats, consolations and finals must be in one direction only Certain Promotions allow turning around on the bends, however, this does not allow a driver to drive the wrong way down the straights. A driver should always check with the Promotion exactly what rules apply at that meeting. (At TSR track, drivers are not allowed to go the wrong way around the track unless the event is a Destruction Derby).The driver can push or spin any car towards the infield or fence, but should not be in contact with the front car if it hits the fence, this may be deemed to be a forceful fencing or follow in, both offences carry a ban. You must not attack any car on the safety area, or attack from the safety area, you must not attack any cars after the red flag or if the stationary yellow is displayed above a car or if the race is under caution (Waved yellow). You must not attack an empty or overturned car. Any damaging collision with a driver's door will result in a penalty.
7. Demolition type events. Any race where the nature of the event is to stop the opposition to win, the following rules apply attacking from the opposition direction is permitted providing the attack is from the outside of the track (fence side). You are also allowed to wait for car or attack any part of the car except the driver area, which is considered to be from the centre of the front wheel to the centre of the rear door driver's side.
8. Demolition Derby rules may only be used when the staging promoter declares by way of drivers briefing, letter or notice in the programme that these rules apply. A Demolition Derby takes place at the end of a meeting. The event is in addition to the normal races at the meeting and does not carry any race points.
9. Drivers who abandon their cars during a race while a race is in progress must retire to a recognised safety area.
10. It is an offence to put or attempt to put an overturned car back onto its wheels during a race, drivers are not allowed to re-enter a car once they have left it. Repairs are not allowed on the circuit and the car must not be pushed or handled in anyway during a race.
11. Team tactics in an individual event will be subject to penalty the decision of the steward will be final.
12. A driver will be held responsible for his or her mechanics or helpers at all times. Drivers will be bound by the decision of the officials in all matters (these items are a condition of booking).
13. Drivers must carry his or her log book at all times.

14. It is an offence for two drivers to share a car at the same meeting, you may only race one car at a meeting unless the promotion allows it as an option for special events.
15. All cars, trim, glass, wheels and tyres must be removed from the Stadium directly after the meeting.
16. In all events the racing must be on track indicated, drivers who try to gain advantage by corner cutting will be penalised or disqualified. Also drivers who continue to drive on and off the safety area will be disqualified.
17. Drivers must comply with any reasonable instruction given by an official of the meeting, failure to do so will result in a penalty or disqualification.
18. Mechanics are not allowed onto the circuit or to repair any competing car. Mechanics are allowed onto the track by invitation of the Clerk of the Course or the Racing Manager only to take part in parades or lap of honour for trophy winners.

T-Boning cars against or near the fence

This type of hit is becoming increasingly common on the National Scene although thankfully we have not had any notable incidents at King's Lynn so far. However, there is no doubt that T-boning a car that is parked against or close to the fence is a particularly dangerous move which could cause serious injury. We will therefore be issuing load-ups to drivers T-boning cars that are parked against or near the fence (or any other immovable object such as a pile of dead cars). This ruling will only apply to drivers judged to have carried out a potentially dangerous hit of this nature. We are not seeking to stop people hitting cars in either wheel or even T-boning a car through the doors as long as this is carried out at a reasonable speed. It's just flat out T-bones through the doors to cars that are pinned in position by the fence or other cars that we will be dealing with. Repeat offenders may be subject to more than a load up.